

EXHIBIT SPECIFICATIONS

LINEAR BOOTH

Linear Booths have only one side exposed to an aisle and are generally arranged in a series along a straight line. They are also called "in-line" booths.

Dimensions

For purposes of consistency and ease of layout and/or reconfiguration, floor plan design in increments of ten feet (10') has become the de facto standard in the United States. Therefore, unless constricted by space or other limitations, Linear Booths are most commonly ten feet (10') wide and ten feet (10') deep, i.e. 10' x 10'. The maximum backwall height limitation is ten feet (10').

Use of Space

Regardless of the number of Linear Booths utilized, (e.g. 10' x 20', 10' x 30', 10' x 40', etc.) display materials should be arranged in such a manner so as not to obstruct sight lines of neighboring exhibitors. The maximum height of twelve feet (12') is allowed only in the rear half of the booth space, with a four-foot (4') height restriction imposed on all materials in the remaining space forward to the aisle. (Note: When three or more Linear Booths are used in combination as a single exhibit space, the four foot (4') height limitation is applied only to that portion of exhibit space which is within ten feet (10') of an adjoining booth.)

Hanging Signs are not permitted over linear booths.

* If your booth exceeds the 8' high back drape it must be professionally finished and free from company ID, booth number and all signage. Any exposed side walls visible over the drape must also be professionally finished.

In-Line (Linear) Booth (Booths 10' x 10')

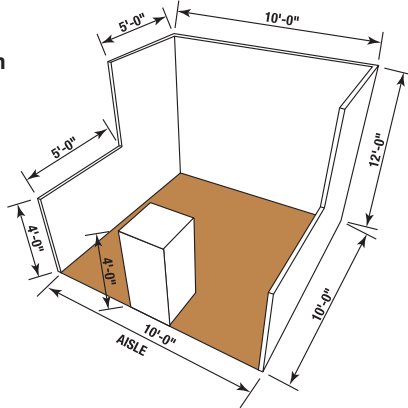

CORNER BOOTH

A Corner Booth is a Linear Booth exposed to aisles on two sides. All other guidelines for Linear Booths apply.

ISLAND BOOTH

An Island Booth is any size booth exposed to aisles on all four sides.

Dimensions

An Island Booth is typically 20' x 20' or larger, although it may be configured differently.

Use of Space

The entire cubic content of the space may be used up to the maximum allowable height, which is twenty-six feet (26') including signage. **Hanging Signs are not permitted over booths smaller than 400 sq. ft.**

Island Booth (Booths 20' x 20' or greater)

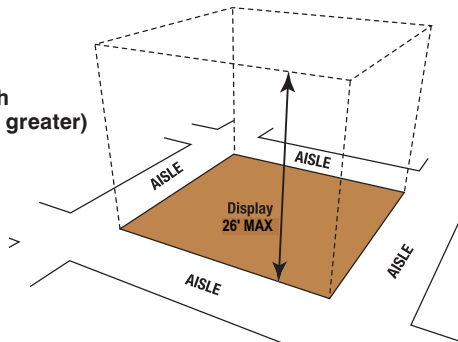

SPLIT ISLAND BOOTH

A Split Island Booth is a Peninsula Booth which shares a common backwall with another Peninsula Booth. The entire cubic content of this booth may be used, up to the maximum allowable height, without any back wall line of sight restrictions. Twenty-six feet (26') is the maximum height allowance including signage. The entire cubic content of the space may be used up to the maximum allowable height. **Hanging Signs are not permitted over booths smaller than 400 sq. ft.**

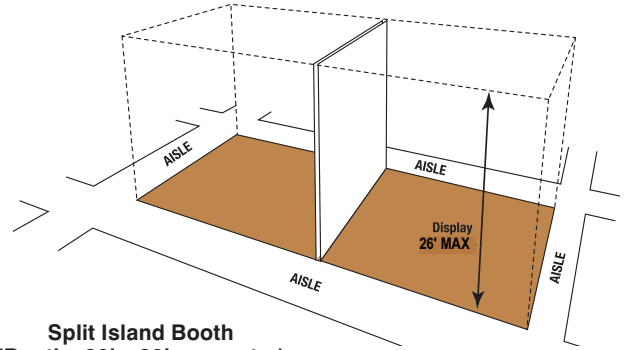

Split Island Booth
(Booths 20' x 20' or greater)

EXHIBITS WITH CEILINGS

If a ceiling will be used in an exhibit, plans must be submitted to Show Management at least 120 days before the show so that approval may be obtained from the Fire Marshal. Failure to submit plans for approval could result in the closing/removal of the exhibitor's booth.

CANOPIES & COVERED CEILINGS

Canopies, including ceilings, umbrellas and canopy frames, can be either decorative or functional (such as to shade computer monitors from ambient light or for hanging products). Canopies for Linear or Perimeter Booths should comply with line of sight requirements (see "Use of Space for Linear or Perimeter Booths").

Canopies

The base of the Canopy should not be lower than seven feet (7') from the floor within five feet (5') of any aisle. Canopy supports should be no wider than three inches (3"). This applies to any booth configuration that has a sightline restriction, such as a Linear Booth. Fire and safety regulations in many facilities strictly govern the use of canopies, ceilings and other similar coverings. Check with the appropriate local agencies prior to determining specific exhibition rules.

In-Line (Linear) Booth with Canopies or Ceilings

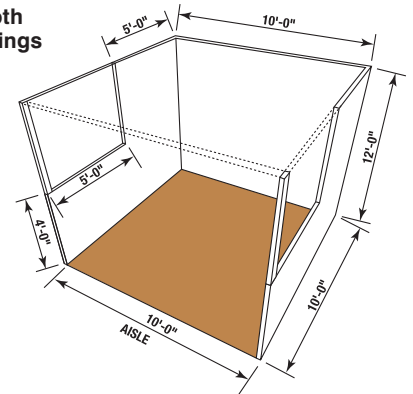

Note: Please see this year's Exhibitor Service Manual for detailed Fire Marshal regulations as it pertains to booth specifications.