

REMODELING SHOW EXHIBIT SPECIFICATIONS

BOOTH CONFIGURATIONS

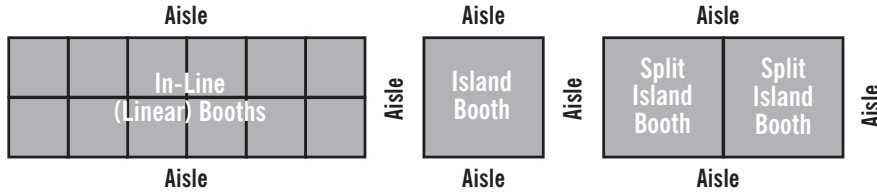

Please review the following booth specifications to ensure that your display meets the Exhibit Specifications. If your booth does not meet these specifications, you must submit a rendering of your display to Show Management for review. All booths, regardless of size, are required to follow these guidelines. For questions regarding booth specifications, please contact Show Management at 972.536.6333. To avoid additional costs (i.e. design cost or tear down of an unapproved structure) please obtain written approval before beginning production or construction of multi-story or covered exhibits. For advance approval and additional information, please email Amy Weller at aweller@hanleywood.com.

LINEAR BOOTH

Linear Booths have only one side exposed to an aisle and are generally arranged in a series along a straight line. They are also called "in-line" booths.

Dimensions

For purposes of consistency and ease of layout and/or reconfiguration, floor plan design in increments of ten feet (10') has become the de facto standard in the United States. Therefore, unless constricted by space or other limitations, Linear Booths are most commonly ten feet (10') wide and ten feet (10') deep, i.e. 10' x 10'. The maximum backwall height limitation is twelve feet (12').

Use of Space

Regardless of the number of Linear Booths utilized, (e.g. 10' x 20', 10' x 30', 10' x 40', etc.) display materials should be arranged in such a manner so as not to obstruct sight lines of neighboring exhibitors. The maximum height of twelve feet (12') is allowed only in the rear half of the booth space, with a four-foot (4') height restriction imposed on all materials in the remaining space forward to the aisle. (Note: When three or more Linear Booths are used in combination as a single exhibit space, the four foot (4') height limitation is applied only to that portion of exhibit space which is within ten feet (10') of an adjoining booth.) **Hanging Signs are not permitted over linear booths.**

* If your booth exceeds the 8' high back drape it must be professionally finished and free from company ID, booth number and all signage. Any exposed side walls visible over the drape must also be professionally finished.

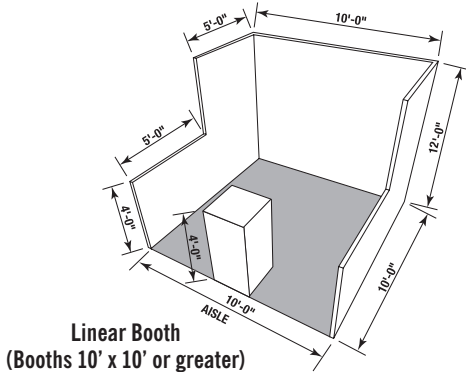

CORNER BOOTH

A Corner Booth is a Linear Booth exposed to aisles on two sides. All other guidelines for Linear Booths apply.

PERIMETER BOOTH

A Perimeter Booth is simply a Linear Booth that backs to a wall of the exhibit facility rather than to another exhibit.

Dimensions and Use of Space

All guidelines for Linear Booths apply to Perimeter Booths.

ISLAND BOOTH

An Island Booth is any size booth exposed to aisles on all four sides.

Dimensions

An Island Booth is typically 20' x 20' or larger, although it may be configured differently.

Use of Space

The entire cubic content of the space may be used up to the maximum allowable height, which is twenty-six feet (26'), including signage. **Hanging Signs are not permitted over booths smaller than 400 sq. ft.**

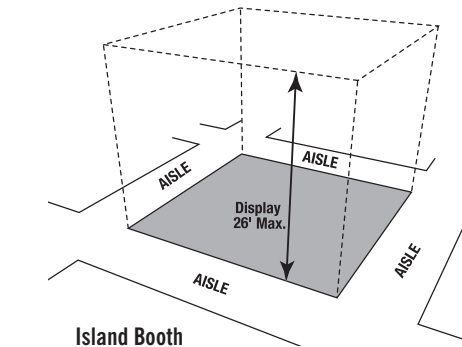

SPLIT ISLAND BOOTH

A Split Island Booth is a Peninsula Booth which shares a common backwall with another Peninsula Booth. The entire cubic content of this booth may be used, up to the maximum allowable height, without any back wall line of sight restrictions. Twenty-six feet (26') is the maximum height allowance including signage. The entire cubic content of the space may be used up to the maximum allowable height. **Hanging Signs are not permitted over booths smaller than 400 sq. ft.**

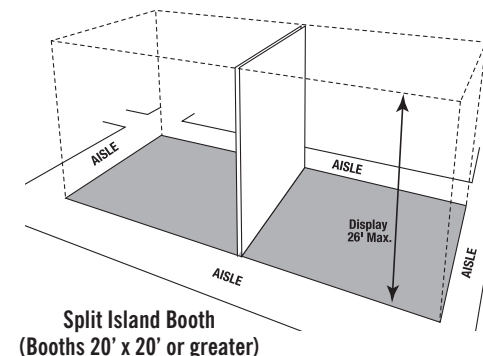

EXHIBITS WITH CEILINGS

If a ceiling will be used in an exhibit, plans must be submitted to Show Management at least 120 days before the show so that approval may be obtained from the Fire Marshal. Failure to submit plans for approval could result in the closing/removal of the exhibitor's booth.

CANOPIES & COVERED CEILINGS

Canopies, including ceilings, umbrellas and canopy frames, can be either decorative or functional (such as to shade computer monitors from ambient light or for hanging products). Canopies for Linear or Perimeter Booths should comply with line of sight requirements (see "Use of Space for Linear or Perimeter Booths").

Canopies

The base of the Canopy should not be lower than seven feet (7') from the floor within five feet (5') of any aisle. Canopy supports should be no wider than three inches (3"). This applies to any booth configuration that has a sightline restriction, such as a Linear Booth. Fire and safety regulations in many facilities strictly govern the use of canopies, ceilings and other similar coverings. Check with the appropriate local agencies prior to determining specific exhibition rules.

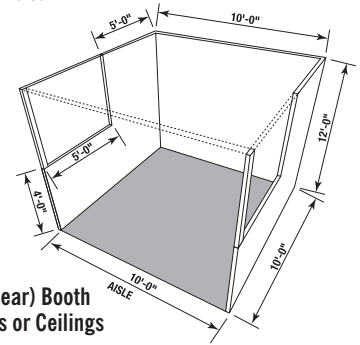

HANGING SIGNS & GRAPHICS

Hanging signs and graphics are permitted over all Island Booths unless the booth is smaller than 400 sq. ft. Whether suspended from above or supported from below, they should comply with all ordinary use-of-space requirements (for example, the highest point of any sign should not exceed the maximum allowable height for the booth type). Hanging Signs & Graphics should be set back ten feet (10') from adjacent booths.

Approval for the use of Hanging Signs & Graphics that fall outside of the stated guidelines will need to obtain approval by Show Management at least 60 days prior to installation. Please contact Show Management at 972.536.6333 to review this information.

TOWERS

A Tower is a freestanding exhibit component separate from the main exhibit fixture. The height restriction is the same as that which applies to the appropriate exhibit configuration being used. Towers in excess of eight feet (8') should have drawings available for inspection. Fire and safety regulations in many facilities strictly govern the use of towers. A building permit may be required.

UNFINISHED WALLS

Any unfinished walls are subject to review by Show Management. Should Show Management deem the backside of the booth "unsightly" and/or does not conform to the overall quality of the show, the exhibitor may be required to drape the backside of the booth at the exhibitor's expense.

NOTE: Regulations for products being featured in booths differ from the booth display regulations. If your product does not meet exhibit specifications, please call Show Management at 972.536.6333.